

# Hydro Classifier box



WELL-TECH EQUIPMENT  
威尔国际矿业装备

## Description

Hydro classifier is a cone angle iron box, some wedge sand block sticks fixed on the upper part, valve fixed at the bottom of classification box. Usually hydro classifier linked together from small size to big size, the precipitated sand discharged from coarse to fine.

It is widely used in hydraulic classification for shaking table, play an important role in classification and material content distribution, in order to improve shaking table's separation efficiency. Hydro classifier has the advantages of simple structure, easy maintenance, no power consumption, reliable performance, easy operation etc.

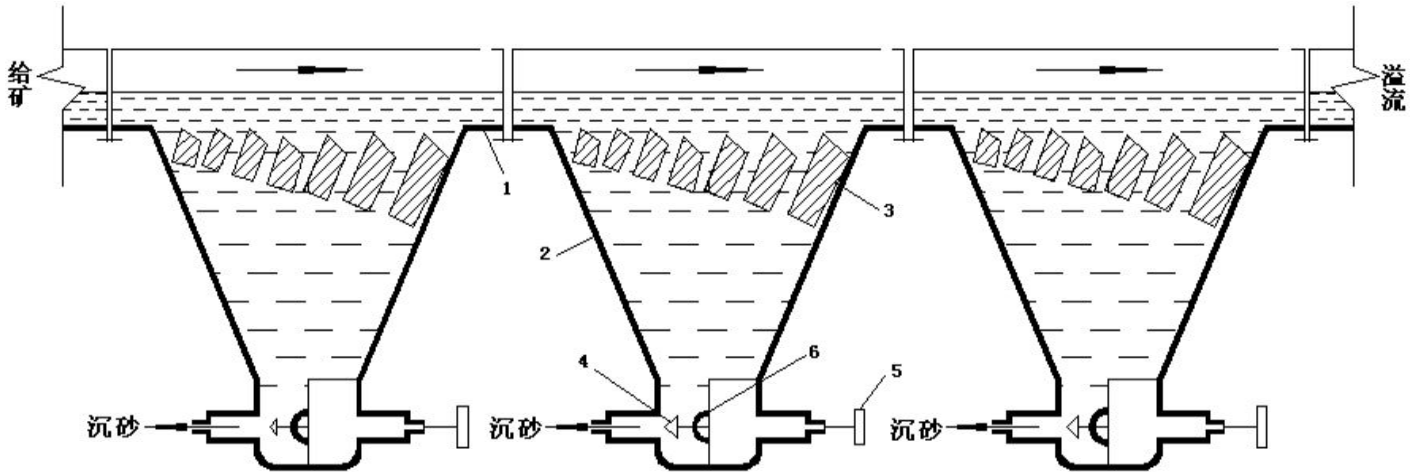

1. Slurry chute 2. Classification box 3. Sand block sticks 4. Sand plug 5. Hand wheel 6. Valve

## Main Technical Parameter

Model	YX-200	YX-300	YX-400	YX-600	YX-800
Number of sand block sticks	11				
Length of sand block sticks (mm)	180	280	380	590	790
Discharge pipe diameter (mm)	25				
Pressure of raise water (kg/cm <sup>2</sup> )	1-2				
Feed size (mm)	2-3				
Feed density (%)	20-25				
Water consumption (m/t)	2-3				
Overall dimensions (mm)	800*200*1000	800*300*1000	800*400*1000	800*600*1000	800*800*1000
Weight (kg)	0.107	0.124	0.148	0.178	0.214

## Application:



mud separate machine